

Features

- Low power consumption
- Low voltage drop
- Low temperature coefficient
- High input voltage (up to 30V)
- Quiescent current 2.5μA
- High output current : 100mA
- Output voltage accuracy: tolerance ±3%
- 3-pin TO92, 3-pin SOT89 and 5-pin SOT23 packages

Applications

- Battery-powered equipment
- Communication equipment
- Audio/Video equipment

General Description

The HT75xx-1 series is a set of three-terminal low power high voltage implemented in CMOS technology. They can deliver 100mA output current and allow an input voltage as high as 30V. They are available with several fixed output voltages ranging from 2.1V to 12.0V. CMOS technology ensures low voltage drop and low quiescent current.

Although designed primarily as fixed voltage regulators, these devices can be used with external components to obtain variable voltages and currents.

Selection Table

Part No.	Output Voltage	Package	Marking
HT7521-1	2.1V	TO92 SOT89 SOT23-5	75xx-1 (for TO92) 75xx-1 (for SOT89) 5xx1 (for SOT23-5)
HT7523-1	2.3V		
HT7525-1	2.5V		
HT7527-1	2.7V		
HT7530-1	3.0V		
HT7533-1	3.3V		
HT7536-1	3.6V		
HT7540-1	4.0V		
HT7544-1	4.4V		
HT7550-1	5.0V		
HT7560-1	6.0V		
HT7570-1	7.0V		
HT7580-1	8.0V		
HT7590-1	9.0V		
HT75A0-1	10.0V		
HT75C0-1	12.0V		

Note: "xx" stands for output voltages.

Block Diagram

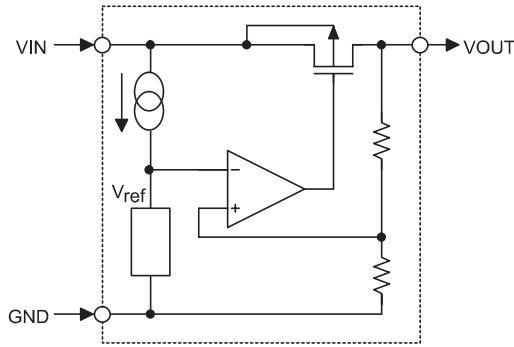

Pin Assignment

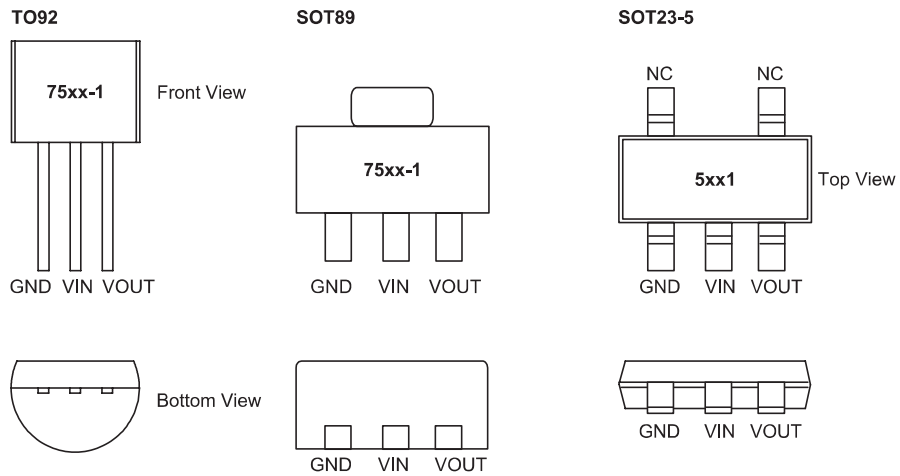

Absolute Maximum Ratings

Supply Voltage -0.3V to 33V Operating Temperature -40°C to 85°C
 Storage Temperature -50°C to 125°C

Note: These are stress ratings only. Stresses exceeding the range specified under "Absolute Maximum Ratings" may cause substantial damage to the device. Functional operation of this device at other conditions beyond those listed in the specification is not implied and prolonged exposure to extreme conditions may affect device reliability.

Thermal Information

Symbol	Parameter	Package	Max.	Unit
θ_{JA}	Thermal Resistance (Junction to Ambient) (Assume no ambient airflow, no heat sink)	SOT23-5	500	°C/W
		SOT89	200	°C/W
		TO92	200	°C/W
P_D	Power Dissipation	SOT23-5	0.20	W
		SOT89	0.50	W
		TO92	0.50	W

Note: P_D is measured at $T_a=25^\circ\text{C}$

Pin Descriptions

Pin No.	Pin Name	Pin Description
1	GND	Ground pin
2	VIN	Input pin
3	VOUT	Output pin

Electrical Characteristics

HT7521-1, +2.1V Output Type

Ta=25°C

Symbol	Parameter	Test Conditions	Min.	Typ.	Max.	Unit
		Conditions				
V _{IN}	Input Voltage	—	—	—	30	V
V _{OUT}	Output Voltage	V _{IN} =4.1V, I _{OUT} =10mA	2.037	2.100	2.163	V
I _{OUT}	Output Current	V _{IN} =4.1V	70	100	—	mA
ΔV _{OUT}	Load Regulation	V _{IN} =4.1V, 1mA ≤ I _{OUT} ≤ 50mA	—	25	60	mV
V _{DIF}	Dropout Voltage ^(Note)	I _{OUT} =1mA, ΔV _{OUT} =2%	—	30	100	mV
I _{SS}	Quiescent Current	No load	—	2.5	4.0	μA
$\frac{\Delta V_{OUT}}{\Delta V_{IN} \times V_{OUT}}$	Line Regulation	3.1V ≤ V _{IN} ≤ 30V, I _{OUT} =1mA	—	—	0.2	%/V
$\frac{\Delta V_{OUT}}{\Delta T_a \times V_{OUT}}$	Temperature Coefficient	I _{OUT} =10mA, -40°C < T _a < 85°C	—	100	—	ppm/°C

Note: Dropout voltage is defined as the input voltage minus the output voltage that produces a 2% change in the output voltage from the value at V_{IN} = V_{OUT}+2V with a fixed load.

HT7523-1, +2.3V Output Type

Ta=25°C

Symbol	Parameter	Test Conditions	Min.	Typ.	Max.	Unit
		Conditions				
V _{IN}	Input Voltage	—	—	—	30	V
V _{OUT}	Output Voltage Tolerance	V _{IN} =4.3V, I _{OUT} =10mA	2.231	2.300	2.369	V
I _{OUT}	Output Current	V _{IN} =4.3V	70	100	—	mA
ΔV _{OUT}	Load Regulation	V _{IN} =4.3V, 1mA ≤ I _{OUT} ≤ 50mA	—	25	60	mV
V _{DIF}	Dropout Voltage ^(Note)	I _{OUT} =1mA, ΔV _{OUT} =2%	—	30	100	mV
I _{SS}	Quiescent Current	No load	—	2.5	4.0	μA
$\frac{\Delta V_{OUT}}{\Delta V_{IN} \times V_{OUT}}$	Line Regulation	3.3V ≤ V _{IN} ≤ 30V, I _{OUT} =1mA	—	—	0.2	%/V
$\frac{\Delta V_{OUT}}{\Delta T_a \times V_{OUT}}$	Temperature Coefficient	I _{OUT} =10mA, -40°C < T _a < 85°C	—	100	—	ppm/°C

Note: Dropout voltage is defined as the input voltage minus the output voltage that produces a 2% change in the output voltage from the value at V_{IN} = V_{OUT}+2V with a fixed load.

HT7525-1, +2.5V Output Type

Ta=25°C

Symbol	Parameter	Test Conditions	Min.	Typ.	Max.	Unit
		Conditions				
V _{IN}	Input Voltage	—	—	—	30	V
V _{OUT}	Output Voltage	V _{IN} =4.5V, I _{OUT} =10mA	2.425	2.500	2.575	V
I _{OUT}	Output Current	V _{IN} =4.5V	70	100	—	mA
ΔV _{OUT}	Load Regulation	V _{IN} =4.5V, 1mA ≤ I _{OUT} ≤ 50mA	—	25	60	mV
V _{DIF}	Dropout Voltage ^(Note)	I _{OUT} =1mA, ΔV _{OUT} =2%	—	30	100	mV
I _{SS}	Quiescent Current	No load	—	2.5	4.0	μA
$\frac{\Delta V_{OUT}}{\Delta V_{IN} \times V_{OUT}}$	Line Regulation	3.5V ≤ V _{IN} ≤ 30V, I _{OUT} =1mA	—	—	0.2	%/V
$\frac{\Delta V_{OUT}}{\Delta T_a \times V_{OUT}}$	Temperature Coefficient	I _{OUT} =10mA, -40°C < T _a < 85°C	—	100	—	ppm/°C

Note: Dropout voltage is defined as the input voltage minus the output voltage that produces a 2% change in the output voltage from the value at V_{IN} = V_{OUT}+2V with a fixed load.

HT7527-1, +2.7V Output Type

Ta=25°C

Symbol	Parameter	Test Conditions	Min.	Typ.	Max.	Unit
		Conditions				
V _{IN}	Input Voltage	—	—	—	30	V
V _{OUT}	Output Voltage	V _{IN} =4.7V, I _{OUT} =10mA	2.619	2.700	2.781	V
I _{OUT}	Output Current	V _{IN} =4.7V	70	100	—	mA
ΔV _{OUT}	Load Regulation	V _{IN} =4.7V, 1mA ≤ I _{OUT} ≤ 50mA	—	25	60	mV
V _{DIF}	Dropout Voltage ^(Note)	I _{OUT} =1mA, ΔV _{OUT} =2%	—	30	100	mV
I _{SS}	Quiescent Current	No load	—	2.5	4.0	μA
$\frac{\Delta V_{OUT}}{\Delta V_{IN} \times V_{OUT}}$	Line Regulation	3.7V ≤ V _{IN} ≤ 30V, I _{OUT} =1mA	—	—	0.2	%/V
$\frac{\Delta V_{OUT}}{\Delta T_a \times V_{OUT}}$	Temperature Coefficient	I _{OUT} =10mA, -40°C < T _a < 85°C	—	100	—	ppm/°C

Note: Dropout voltage is defined as the input voltage minus the output voltage that produces a 2% change in the output voltage from the value at V_{IN} = V_{OUT}+2V with a fixed load.

HT7530-1, +3.0V Output Type

Ta=25°C

Symbol	Parameter	Test Conditions	Min.	Typ.	Max.	Unit
		Conditions				
V _{IN}	Input Voltage	—	—	—	30	V
V _{OUT}	Output Voltage	V _{IN} =5.0V, I _{OUT} =10mA	2.910	3.000	3.090	V
I _{OUT}	Output Current	V _{IN} =5.0V	70	100	—	mA
ΔV _{OUT}	Load Regulation	V _{IN} =5.0V, 1mA ≤ I _{OUT} ≤ 50mA	—	25	60	mV
V _{DIF}	Dropout Voltage ^(Note)	I _{OUT} =1mA, ΔV _{OUT} =2%	—	30	100	mV
I _{SS}	Quiescent Current	No load	—	2.5	4.0	μA
$\frac{\Delta V_{OUT}}{\Delta V_{IN} \times V_{OUT}}$	Line Regulation	4.0V ≤ V _{IN} ≤ 30V, I _{OUT} =1mA	—	—	0.2	%/V
$\frac{\Delta V_{OUT}}{\Delta T_a \times V_{OUT}}$	Temperature Coefficient	I _{OUT} =10mA, -40°C < T _a < 85°C	—	100	—	ppm/°C

Note: Dropout voltage is defined as the input voltage minus the output voltage that produces a 2% change in the output voltage from the value at V_{IN} = V_{OUT}+2V with a fixed load.

HT7533-1, +3.3V Output Type

Ta=25°C

Symbol	Parameter	Test Conditions	Min.	Typ.	Max.	Unit
		Conditions				
V _{IN}	Input Voltage	—	—	—	30	V
V _{OUT}	Output Voltage	V _{IN} =5.3V, I _{OUT} =10mA	3.201	3.300	3.399	V
I _{OUT}	Output Current	V _{IN} =5.3V	70	100	—	mA
ΔV _{OUT}	Load Regulation	V _{IN} =5.3V, 1mA ≤ I _{OUT} ≤ 50mA	—	25	60	mV
V _{DIF}	Dropout Voltage ^(Note)	I _{OUT} =1mA, ΔV _{OUT} =2%	—	25	55	mV
I _{SS}	Quiescent Current	No load	—	2.5	4.0	μA
$\frac{\Delta V_{OUT}}{\Delta V_{IN} \times V_{OUT}}$	Line Regulation	4.3V ≤ V _{IN} ≤ 30V, I _{OUT} =1mA	—	—	0.2	%/V
$\frac{\Delta V_{OUT}}{\Delta T_a \times V_{OUT}}$	Temperature Coefficient	I _{OUT} =10mA, -40°C < T _a < 85°C	—	100	—	ppm/°C

Note: Dropout voltage is defined as the input voltage minus the output voltage that produces a 2% change in the output voltage from the value at V_{IN} = V_{OUT}+2V with a fixed load.

HT7536-1, +3.6V Output Type

Ta=25°C

Symbol	Parameter	Test Conditions	Min.	Typ.	Max.	Unit
		Conditions				
V _{IN}	Input Voltage	—	—	—	30	V
V _{OUT}	Output Voltage	V _{IN} =5.6V, I _{OUT} =10mA	3.492	3.600	3.708	V
I _{OUT}	Output Current	V _{IN} =5.6V	70	100	—	mA
ΔV _{OUT}	Load Regulation	V _{IN} =5.6V, 1mA ≤ I _{OUT} ≤ 50mA	—	25	60	mV
V _{DIF}	Dropout Voltage ^(Note)	I _{OUT} =1mA, ΔV _{OUT} =2%	—	25	55	mV
I _{SS}	Quiescent Current	No load	—	2.5	4.0	μA
$\frac{\Delta V_{OUT}}{\Delta V_{IN} \times V_{OUT}}$	Line Regulation	4.6V ≤ V _{IN} ≤ 30V, I _{OUT} =1mA	—	—	0.2	%/V
$\frac{\Delta V_{OUT}}{\Delta T_a \times V_{OUT}}$	Temperature Coefficient	I _{OUT} =10mA, -40°C < T _a < 85°C	—	100	—	ppm/°C

Note: Dropout voltage is defined as the input voltage minus the output voltage that produces a 2% change in the output voltage from the value at V_{IN} = V_{OUT}+2V with a fixed load.

HT7540-1, +4.0V Output Type

Ta=25°C

Symbol	Parameter	Test Conditions	Min.	Typ.	Max.	Unit
		Conditions				
V _{IN}	Input Voltage	—	—	—	30	V
V _{OUT}	Output Voltage	V _{IN} =6.0V, I _{OUT} =10mA	3.880	4.000	4.120	V
I _{OUT}	Output Current	V _{IN} =6.0V	70	100	—	mA
ΔV _{OUT}	Load Regulation	V _{IN} =6.0V, 1mA ≤ I _{OUT} ≤ 50mA	—	25	60	mV
V _{DIF}	Dropout Voltage ^(Note)	I _{OUT} =1mA, ΔV _{OUT} =2%	—	25	55	mV
I _{SS}	Quiescent Current	No load	—	2.5	4.0	μA
$\frac{\Delta V_{OUT}}{\Delta V_{IN} \times V_{OUT}}$	Line Regulation	5.0V ≤ V _{IN} ≤ 30V, I _{OUT} =1mA	—	—	0.2	%/V
$\frac{\Delta V_{OUT}}{\Delta T_a \times V_{OUT}}$	Temperature Coefficient	I _{OUT} =10mA, -40°C < T _a < 85°C	—	100	—	ppm/°C

Note: Dropout voltage is defined as the input voltage minus the output voltage that produces a 2% change in the output voltage from the value at V_{IN} = V_{OUT}+2V with a fixed load.

HT7544-1, +4.4V Output Type

Ta=25°C

Symbol	Parameter	Test Conditions	Min.	Typ.	Max.	Unit
		Conditions				
V _{IN}	Input Voltage	—	—	—	30	V
V _{OUT}	Output Voltage	V _{IN} =6.4V, I _{OUT} =10mA	4.268	4.400	4.532	V
I _{OUT}	Output Current	V _{IN} =6.4V	70	100	—	mA
ΔV _{OUT}	Load Regulation	V _{IN} =6.4V, 1mA ≤ I _{OUT} ≤ 50mA	—	25	60	mV
V _{DIF}	Dropout Voltage ^(Note)	I _{OUT} =1mA, ΔV _{OUT} =2%	—	25	55	mV
I _{SS}	Quiescent Current	No load	—	2.5	4.0	μA
$\frac{\Delta V_{OUT}}{\Delta V_{IN} \times V_{OUT}}$	Line Regulation	5.4V ≤ V _{IN} ≤ 30V, I _{OUT} =1mA	—	—	0.2	%/V
$\frac{\Delta V_{OUT}}{\Delta T_a \times V_{OUT}}$	Temperature Coefficient	I _{OUT} =10mA, -40°C < T _a < 85°C	—	100	—	ppm/°C

Note: Dropout voltage is defined as the input voltage minus the output voltage that produces a 2% change in the output voltage from the value at V_{IN} = V_{OUT}+2V with a fixed load.

HT7550-1, +5.0V Output Type

Ta=25°C

Symbol	Parameter	Test Conditions	Min.	Typ.	Max.	Unit
		Conditions				
V _{IN}	Input Voltage	—	—	—	30	V
V _{OUT}	Output Voltage	V _{IN} =7.0V, I _{OUT} =10mA	4.850	5.000	5.150	V
I _{OUT}	Output Current	V _{IN} =7.0V	100	150	—	mA
ΔV _{OUT}	Load Regulation	V _{IN} =7.0V, 1mA ≤ I _{OUT} ≤ 70mA	—	25	60	mV
V _{DIF}	Dropout Voltage ^(Note)	I _{OUT} =1mA, ΔV _{OUT} =2%	—	25	55	mV
I _{SS}	Quiescent Current	No load	—	2.5	4.0	μA
$\frac{\Delta V_{OUT}}{\Delta V_{IN} \times V_{OUT}}$	Line Regulation	6.0V ≤ V _{IN} ≤ 30V, I _{OUT} =1mA	—	—	0.2	%/V
$\frac{\Delta V_{OUT}}{\Delta T_a \times V_{OUT}}$	Temperature Coefficient	I _{OUT} =10mA, -40°C < T _a < 85°C	—	100	—	ppm/°C

Note: Dropout voltage is defined as the input voltage minus the output voltage that produces a 2% change in the output voltage from the value at V_{IN} = V_{OUT}+2V with a fixed load.

HT7560-1, +6.0V Output Type

Ta=25°C

Symbol	Parameter	Test Conditions	Min.	Typ.	Max.	Unit
		Conditions				
V _{IN}	Input Voltage	—	—	—	30	V
V _{OUT}	Output Voltage	V _{IN} =8.0V, I _{OUT} =10mA	5.820	6.000	6.180	V
I _{OUT}	Output Current	V _{IN} =8.0V	150	—	—	mA
ΔV _{OUT}	Load Regulation	V _{IN} =8.0V, 1mA ≤ I _{OUT} ≤ 70mA	—	25	60	mV
V _{DIF}	Dropout Voltage ^(Note)	I _{OUT} =1mA, ΔV _{OUT} =2%	—	25	55	mV
I _{SS}	Quiescent Current	No load	—	2.5	4.0	μA
$\frac{\Delta V_{OUT}}{\Delta V_{IN} \times V_{OUT}}$	Line Regulation	7.0V ≤ V _{IN} ≤ 30V, I _{OUT} =1mA	—	0.2	—	%/V
$\frac{\Delta V_{OUT}}{\Delta T_a \times V_{OUT}}$	Temperature Coefficient	I _{OUT} =10mA, -40°C < T _a < 85°C	—	100	—	ppm/°C

Note: Dropout voltage is defined as the input voltage minus the output voltage that produces a 2% change in the output voltage from the value at V_{IN} = V_{OUT} + 2V with a fixed load.

HT7570-1, +7.0V Output Type

Ta=25°C

Symbol	Parameter	Test Conditions	Min.	Typ.	Max.	Unit
		Conditions				
V _{IN}	Input Voltage	—	—	—	30	V
V _{OUT}	Output Voltage	V _{IN} =9.0V, I _{OUT} =10mA	6.790	7.000	7.210	V
I _{OUT}	Output Current	V _{IN} =9.0V	150	—	—	mA
ΔV _{OUT}	Load Regulation	V _{IN} =9.0V, 1mA ≤ I _{OUT} ≤ 70mA	—	25	60	mV
V _{DIF}	Dropout Voltage ^(Note)	I _{OUT} =1mA, ΔV _{OUT} =2%	—	25	55	mV
I _{SS}	Quiescent Current	No load	—	2.5	4.0	μA
$\frac{\Delta V_{OUT}}{\Delta V_{IN} \times V_{OUT}}$	Line Regulation	8.0V ≤ V _{IN} ≤ 30V, I _{OUT} =1mA	—	0.2	—	%/V
$\frac{\Delta V_{OUT}}{\Delta T_a \times V_{OUT}}$	Temperature Coefficient	I _{OUT} =10mA, -40°C < T _a < 85°C	—	100	—	ppm/°C

Note: Dropout voltage is defined as the input voltage minus the output voltage that produces a 2% change in the output voltage from the value at V_{IN} = V_{OUT} + 2V with a fixed load.

HT7580-1, +8.0V Output Type

Ta=25°C

Symbol	Parameter	Test Conditions	Min.	Typ.	Max.	Unit
		Conditions				
V _{IN}	Input Voltage	—	—	—	30	V
V _{OUT}	Output Voltage	V _{IN} =10.0V, I _{OUT} =10mA	7.760	8.000	8.240	V
I _{OUT}	Output Current	V _{IN} =10.0V	150	—	—	mA
ΔV _{OUT}	Load Regulation	V _{IN} =10.0V, 1mA ≤ I _{OUT} ≤ 70mA	—	25	60	mV
V _{DIF}	Dropout Voltage ^(Note)	I _{OUT} =1mA, ΔV _{OUT} =2%	—	25	55	mV
I _{SS}	Quiescent Current	No load	—	2.5	4.0	μA
$\frac{\Delta V_{OUT}}{\Delta V_{IN} \times V_{OUT}}$	Line Regulation	9.0V ≤ V _{IN} ≤ 30V, I _{OUT} =1mA	—	0.2	—	%/V
$\frac{\Delta V_{OUT}}{\Delta T_a \times V_{OUT}}$	Temperature Coefficient	I _{OUT} =10mA, -40°C < T _a < 85°C	—	100	—	ppm/°C

Note: Dropout voltage is defined as the input voltage minus the output voltage that produces a 2% change in the output voltage from the value at V_{IN} = V_{OUT}+2V with a fixed load.

HT7590-1, +9.0V Output Type

Ta=25°C

Symbol	Parameter	Test Conditions	Min.	Typ.	Max.	Unit
		Conditions				
V _{IN}	Input Voltage	—	—	—	30	V
V _{OUT}	Output Voltage	V _{IN} =11.0V, I _{OUT} =10mA	8.730	9.000	9.270	V
I _{OUT}	Output Current	V _{IN} =11.0V	150	—	—	mA
ΔV _{OUT}	Load Regulation	V _{IN} =11.0V, 1mA ≤ I _{OUT} ≤ 70mA	—	25	70	mV
V _{DIF}	Dropout Voltage ^(Note)	I _{OUT} =1mA, ΔV _{OUT} =2%	—	25	55	mV
I _{SS}	Quiescent Current	No load	—	2.5	4.0	μA
$\frac{\Delta V_{OUT}}{\Delta V_{IN} \times V_{OUT}}$	Line Regulation	10.0V ≤ V _{IN} ≤ 30V, I _{OUT} =1mA	—	0.2	—	%/V
$\frac{\Delta V_{OUT}}{\Delta T_a \times V_{OUT}}$	Temperature Coefficient	I _{OUT} =10mA, -40°C < T _a < 85°C	—	100	—	ppm/°C

Note: Dropout voltage is defined as the input voltage minus the output voltage that produces a 2% change in the output voltage from the value at V_{IN} = V_{OUT}+2V with a fixed load.

HT75A0-1, +10.0V Output Type

Ta=25°C

Symbol	Parameter	Test Conditions	Min.	Typ.	Max.	Unit
		Conditions				
V _{IN}	Input Voltage	—	—	—	30	V
V _{OUT}	Output Voltage	V _{IN} =12.0V, I _{OUT} =10mA	9.700	10.000	10.300	V
I _{OUT}	Output Current	V _{IN} =12.0V	150	—	—	mA
ΔV _{OUT}	Load Regulation	V _{IN} =12.0V, 1mA ≤ I _{OUT} ≤ 70mA	—	25	70	mV
V _{DIF}	Dropout Voltage ^(Note)	I _{OUT} =1mA, ΔV _{OUT} =2%	—	25	55	mV
I _{SS}	Quiescent Current	No load	—	2.5	4.0	μA
$\frac{\Delta V_{OUT}}{\Delta V_{IN} \times V_{OUT}}$	Line Regulation	11.0V ≤ V _{IN} ≤ 30V, I _{OUT} =1mA	—	0.2	—	%/V
$\frac{\Delta V_{OUT}}{\Delta T_a \times V_{OUT}}$	Temperature Coefficient	I _{OUT} =10mA, -40°C < T _a < 85°C	—	100	—	ppm/°C

Note: Dropout voltage is defined as the input voltage minus the output voltage that produces a 2% change in the output voltage from the value at V_{IN} = V_{OUT}+2V with a fixed load.

HT75C0-1, +12.0V Output Type

Ta=25°C

Symbol	Parameter	Test Conditions	Min.	Typ.	Max.	Unit
		Conditions				
V _{IN}	Input Voltage	—	—	—	30	V
V _{OUT}	Output Voltage	V _{IN} =14.0V, I _{OUT} =10mA	11.640	12.000	12.360	V
I _{OUT}	Output Current	V _{IN} =14.0V	150	—	—	mA
ΔV _{OUT}	Load Regulation	V _{IN} =14.0V, 1mA ≤ I _{OUT} ≤ 70mA	—	25	70	mV
V _{DIF}	Dropout Voltage ^(Note)	I _{OUT} =1mA, ΔV _{OUT} =2%	—	25	55	mV
I _{SS}	Quiescent Current	No load	—	2.5	4.0	μA
$\frac{\Delta V_{OUT}}{\Delta V_{IN} \times V_{OUT}}$	Line Regulation	13.0V ≤ V _{IN} ≤ 30V, I _{OUT} =1mA	—	0.2	—	%/V
$\frac{\Delta V_{OUT}}{\Delta T_a \times V_{OUT}}$	Temperature Coefficient	I _{OUT} =10mA, -40°C < T _a < 85°C	—	100	—	ppm/°C

Note: Dropout voltage is defined as the input voltage minus the output voltage that produces a 2% change in the output voltage from the value at V_{IN} = V_{OUT}+2V with a fixed load.

Typical Performance Characteristics

Test Condition: $V_{in}=V_{out}+2V$, $I_{OUT}=10mA$, $T_f=25^{\circ}C$, unless otherwise noted

Output Voltage vs Input Voltage

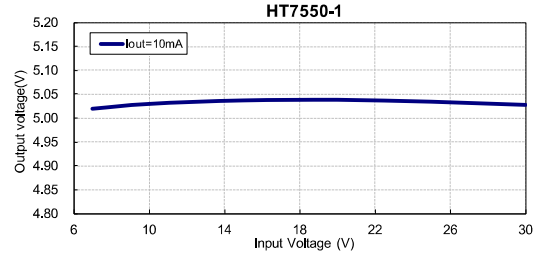
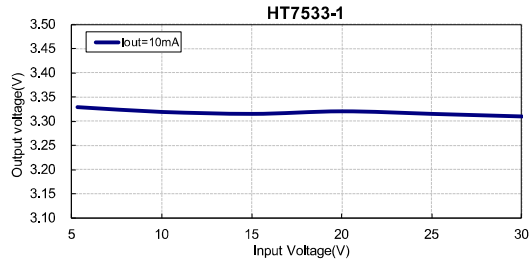

Quiescent current (Iout=0mA) vs Temperature

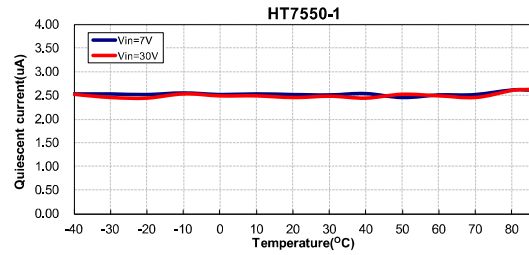
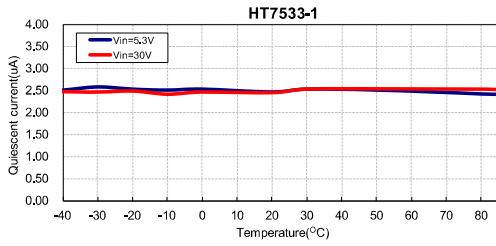

Output Voltage vs Temperature

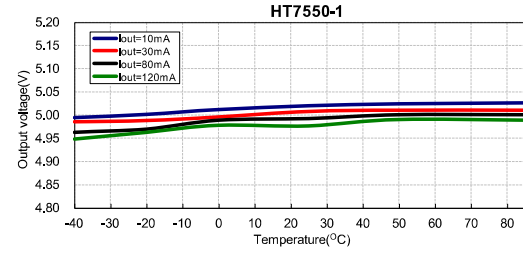
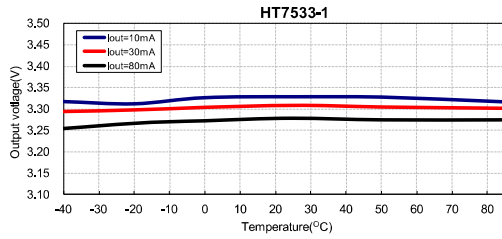

Output Voltage vs Temperature

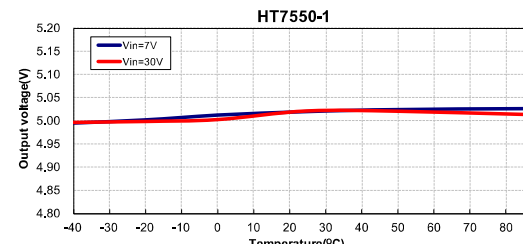
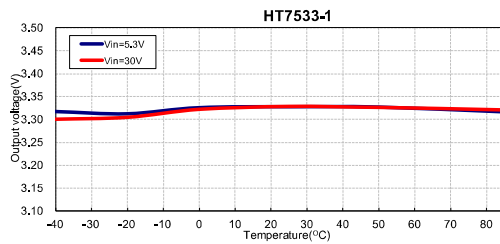

Application Circuits

Basic Circuit

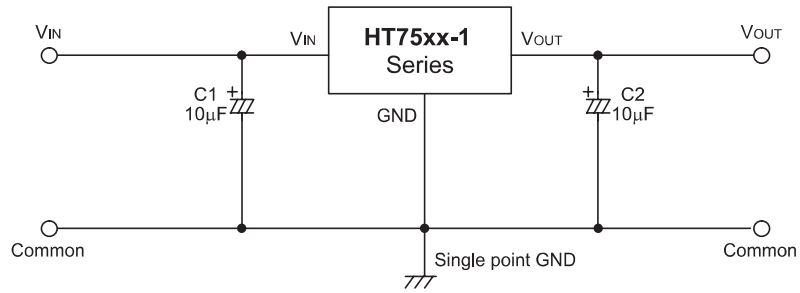

High Output Current Positive Voltage Regulator

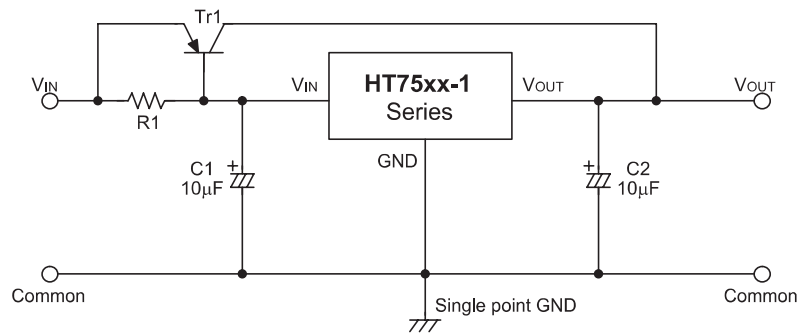

Short-Circuit Protection for $Tr1$

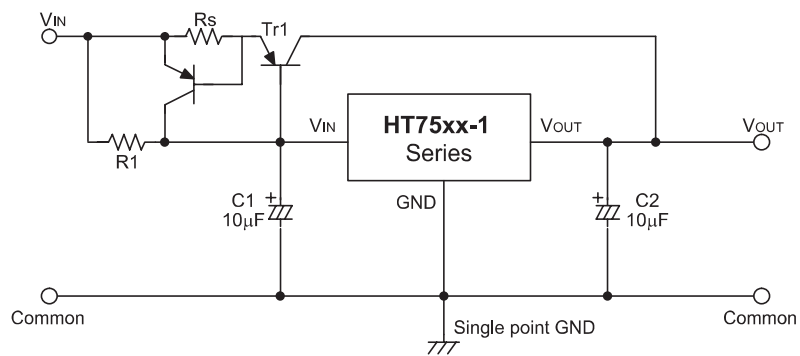

Circuit for Increasing Output Voltage

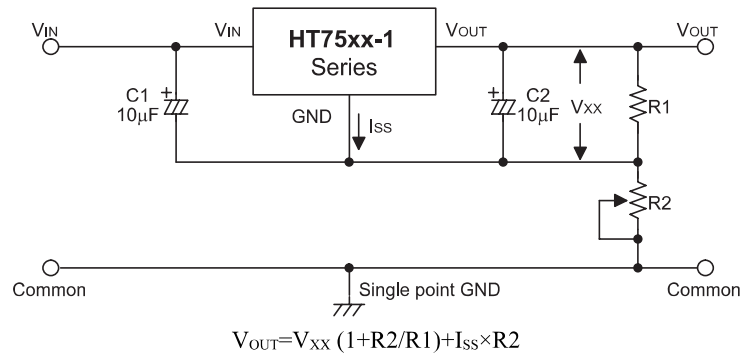

Circuit for Increasing Output Voltage

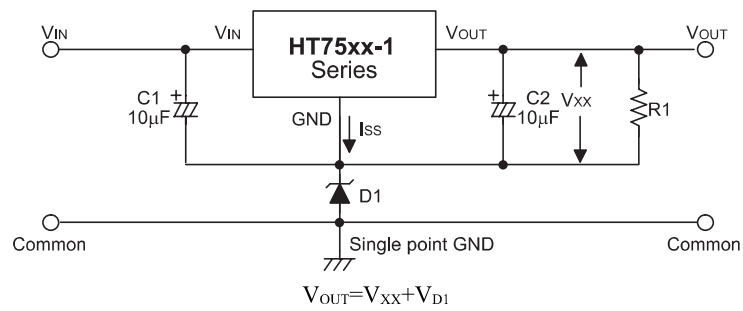

Constant Current Regulator

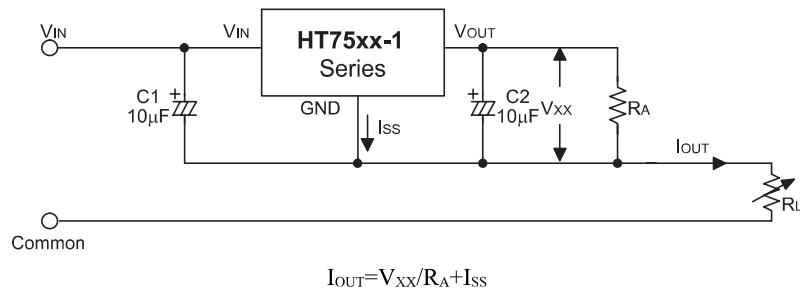

Dual Supply

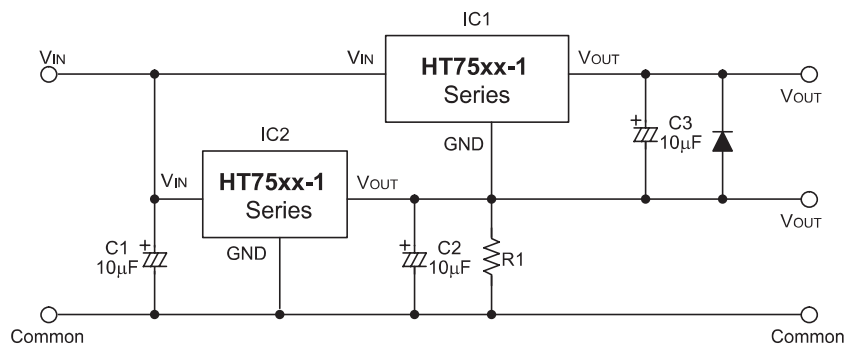

Package Information

Note that the package information provided here is for consultation purposes only. As this information may be updated at regular intervals users are reminded to consult the [Holtek website](#) for the latest version of the [Package/ Carton Information](#).

Additional supplementary information with regard to packaging is listed below. Click on the relevant section to be transferred to the relevant website page.

- Further Package Information (include Outline Dimensions, Product Tape and Reel Specifications)
- Packing Materials Information
- Carton information

3-pin TO92 Outline Dimensions

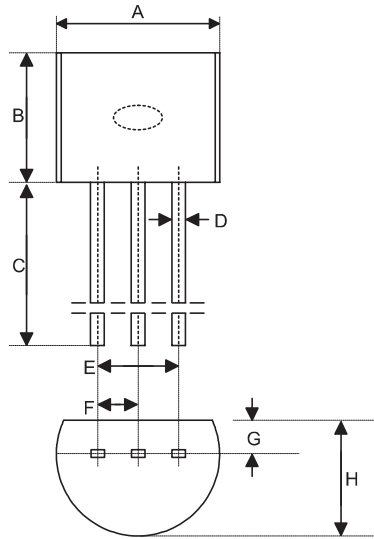

Symbol	Dimensions in inch		
	Min.	Nom.	Max.
A	0.173	0.180	0.205
B	0.170	—	0.210
C	0.500	0.580	—
D	—	0.015 BSC	—
E	—	0.010 BSC	—
F	—	0.050 BSC	—
G	—	0.035 BSC	—
H	0.125	0.142	0.165

Symbol	Dimensions in mm		
	Min.	Nom.	Max.
A	4.39	4.57	5.21
B	4.32	—	5.33
C	12.70	14.73	—
D	—	0.38 BSC	—
E	—	2.54 BSC	—
F	—	1.27 BSC	—
G	—	0.89 BSC	—
H	3.18	3.61	4.19

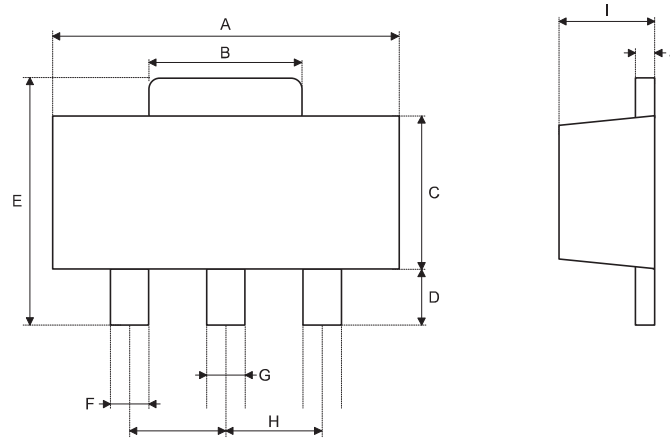
3-pin SOT89 Outline Dimensions

Symbol	Dimensions in inch		
	Min.	Nom.	Max.
A	0.173	—	0.185
B	0.053	—	0.072
C	0.090	—	0.106
D	0.031	—	0.047
E	0.155	—	0.173
F	0.014	—	0.019
G	0.017	—	0.022
H	—	0.059 BSC	—
I	0.055	—	0.063
J	0.014	—	0.017

Symbol	Dimensions in mm		
	Min.	Nom.	Max.
A	4.40	—	4.70
B	1.35	—	1.83
C	2.29	—	2.70
D	0.89	—	1.20
E	3.94	—	4.40
F	0.36	—	0.48
G	0.44	—	0.56
H	—	1.50 BSC	—
I	1.40	—	1.60
J	0.35	—	0.44

5-pin SOT23 Outline Dimensions

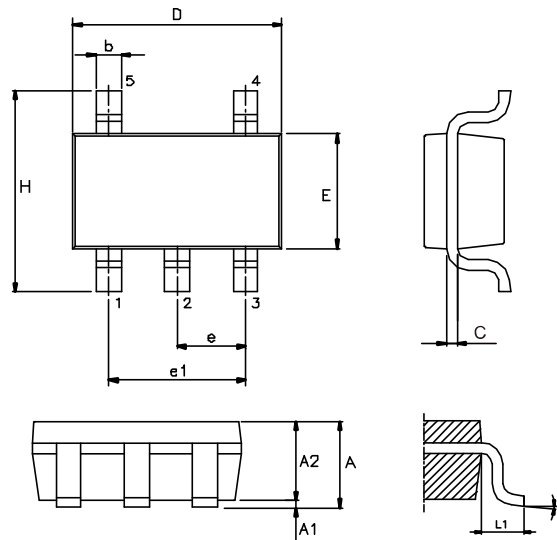

Symbol	Dimensions in inch		
	Min.	Nom.	Max.
A	—	—	0.057
A1	—	—	0.006
A2	0.035	0.045	0.051
b	0.012	—	0.020
C	0.003	—	0.009
D	—	0.114 BSC	—
E	—	0.063 BSC	—
e	—	0.037 BSC	—
e1	—	0.075 BSC	—
H	—	0.110 BSC	—
L1	—	0.024 BSC	—
θ	0°	—	8°

Symbol	Dimensions in mm		
	Min.	Nom.	Max.
A	—	—	1.45
A1	—	—	0.15
A2	0.90	1.15	1.30
b	0.30	—	0.50
C	0.08	—	0.22
D	—	2.90 BSC	—
E	—	1.60 BSC	—
e	—	0.95 BSC	—
e1	—	1.90 BSC	—
H	—	2.80 BSC	—
L1	—	0.60 BSC	—
θ	0°	—	8°

Copyright© 2018 by HOLTEK SEMICONDUCTOR INC.

The information appearing in this Data Sheet is believed to be accurate at the time of publication. However, Holtek assumes no responsibility arising from the use of the specifications described. The applications mentioned herein are used solely for the purpose of illustration and Holtek makes no warranty or representation that such applications will be suitable without further modification, nor recommends the use of its products for application that may present a risk to human life due to malfunction or otherwise. Holtek's products are not authorized for use as critical components in life support devices or systems. Holtek reserves the right to alter its products without prior notification. For the most up-to-date information, please visit our web site at <http://www.holtek.com.tw>.