

1.2 V to 37 V adjustable voltage regulators

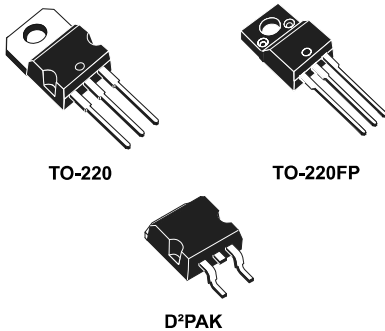

Features

- Output voltage range: 1.2 to 37 V
- Output current in excess of 1.5 A
- 0.1% line and load regulation
- Floating operation for high voltages
- Complete series of protections: current limiting, thermal shutdown and SOA control

Description

The LM217, LM317 are monolithic integrated circuits in TO-220, TO-220FP and D²PAK packages intended for use as positive adjustable voltage regulators.

They are designed to supply more than 1.5 A of load current with an output voltage adjustable over a 1.2 to 37 V range.

The nominal output voltage is selected by means of a resistive divider, making the device exceptionally easy to use and eliminating the stocking of many fixed regulators.

Product status link

[LM217](#)[LM317](#)

1 Pin configuration

Figure 1. Pin connections (top view)

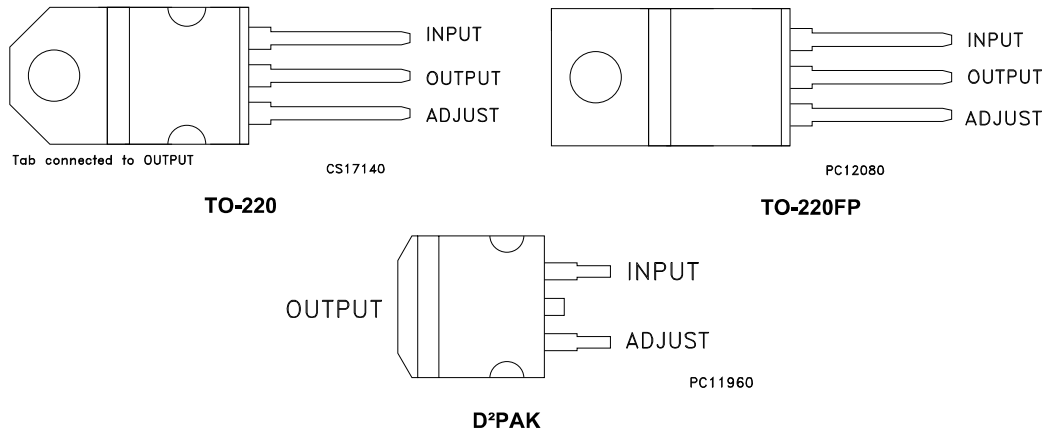

2 Maximum ratings

Table 1. Absolute maximum ratings

Symbol	Parameter	Value	Unit
$V_I - V_O$	Input-reference differential voltage	40	V
I_O	Output current	Internally limited	A
T_{OP}	Operating junction temperature for:	LM217	- 25 to 150
		LM317	0 to 125
		LM317B	-40 to 125
P_D	Power dissipation	Internally limited	
T_{STG}	Storage temperature	- 65 to 150	°C

Note: Absolute maximum ratings are those values beyond which damage to the device may occur. Functional operation under these condition is not implied.

Table 2. Thermal data

Symbol	Parameter	D ² PAK	TO-220	TO-220FP	Unit
R_{thJA}	Thermal resistance junction-ambient	62.5	50	60	°C/W
R_{thJC}	Thermal resistance junction-case	3	5	5	°C/W

3 Diagram

Figure 2. Schematic diagram

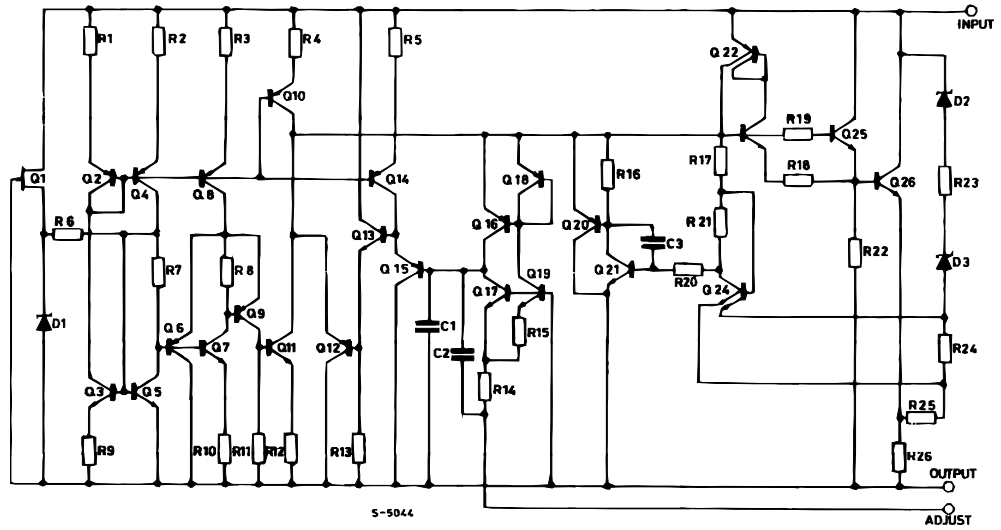

4 Electrical characteristics

$V_I - V_O = 5\text{ V}$, $I_O = 500\text{ mA}$, $I_{MAX} = 1.5\text{ A}$ and $P_{MAX} = 20\text{ W}$, $T_J = -25\text{ to }150\text{ }^\circ\text{C}$, unless otherwise specified.

Table 3. Electrical characteristics for LM217

Symbol	Parameter	Test conditions	Min.	Typ.	Max.	Unit	
ΔV_O	Line regulation	$V_I - V_O = 3\text{ to }40\text{ V}$	$T_J = 25^\circ\text{C}$		0.01	0.02	%V
					0.02	0.05	
ΔV_O	Load regulation	$V_O \leq 5\text{ V}$ $I_O = 10\text{ mA to }I_{MAX}$	$T_J = 25^\circ\text{C}$		5	15	mV
					20	50	
		$V_O \geq 5\text{ V}$, $I_O = 10\text{ mA to }I_{MAX}$	$T_J = 25^\circ\text{C}$		0.1	0.3	%
					0.3	1	
I_{ADJ}	Adjustment pin current			50	100	μA	
ΔI_{ADJ}	Adjustment pin current	$V_I - V_O = 2.5\text{ to }40\text{ V}$ $I_O = 10\text{ mA to }I_{MAX}$		0.2	5	μA	
V_{REF}	Reference voltage	$V_I - V_O = 2.5\text{ to }40\text{ V}$ $I_O = 10\text{ mA to }I_{MAX}$ $P_D \leq P_{MAX}$	1.2	1.25	1.3	V	
$\Delta V_O/V_O$	Output voltage temperature stability			1		%	
$I_{O(min)}$	Minimum load current	$V_I - V_O = 40\text{ V}$		3.5	5	mA	
$I_{O(max)}$	Maximum load current	$V_I - V_O \leq 15\text{ V}$, $P_D < P_{MAX}$	1.5	2.2		A	
		$V_I - V_O = 40\text{ V}$, $P_D < P_{MAX}$, $T_J = 25^\circ\text{C}$		0.4			
eN	Output noise voltage (percentage of V_O)	$B = 10\text{ Hz to }100\text{ kHz}$, $T_J = 25^\circ\text{C}$		0.003		%	
SVR	Supply voltage rejection ⁽¹⁾	$T_J = 25^\circ\text{C}$, $f = 120\text{ Hz}$	$C_{ADJ} = 0$		65	dB	
			$C_{ADJ} = 10\text{ }\mu\text{F}$	66	80		

1. C_{ADJ} is connected between adjust pin and ground.

$V_I - V_O = 5\text{ V}$, $I_O = 500\text{ mA}$, $I_{MAX} = 1.5\text{ A}$ and $P_{MAX} = 20\text{ W}$, $T_J = 0\text{ to }125\text{ }^\circ\text{C}$, unless otherwise specified.

Table 4. Electrical characteristics for LM317

Symbol	Parameter	Test conditions	Min.	Typ.	Max.	Unit
ΔV_O	Line regulation	$V_I - V_O = 3\text{ to }40\text{ V}$	$T_J = 25^\circ\text{C}$	0.01	0.04	%V
				0.02	0.07	
ΔV_O	Load regulation	$V_O \leq 5\text{ V}$ $I_O = 10\text{ mA to }I_{MAX}$	$T_J = 25^\circ\text{C}$	5	25	mV
				20	70	
		$V_O \geq 5\text{ V}$, $I_O = 10\text{ mA to }I_{MAX}$	$T_J = 25^\circ\text{C}$	0.1	0.5	%
				0.3	1.5	
I_{ADJ}	Adjustment pin current		50	100	μA	
ΔI_{ADJ}	Adjustment pin current	$V_I - V_O = 2.5\text{ to }40\text{ V}$ $I_O = 10\text{ mA to }I_{MAX}$		0.2	5	μA
V_{REF}	Reference voltage (between pin 3 and pin 1)	$V_I - V_O = 2.5\text{ to }40\text{ V}$ $I_O = 10\text{ mA to }I_{MAX}$ $P_D \leq P_{MAX}$	1.2	1.25	1.3	V
$\Delta V_O/V_O$	Output voltage temperature stability			1		%
$I_{O(min)}$	Minimum load current	$V_I - V_O = 40\text{ V}$		3.5	10	mA
$I_{O(max)}$	Maximum load current	$V_I - V_O \leq 15\text{ V}$, $P_D < P_{MAX}$	1.5	2.2		A
		$V_I - V_O = 40\text{ V}$, $P_D < P_{MAX}$, $T_J = 25^\circ\text{C}$	0.4			
eN	Output noise voltage (percentage of V_O)	$B = 10\text{ Hz to }100\text{ kHz}$, $T_J = 25^\circ\text{C}$		0.003		%
SVR	Supply voltage rejection ⁽¹⁾	$T_J = 25^\circ\text{C}$, $f = 120\text{ Hz}$	$C_{ADJ} = 0$		65	dB
			$C_{ADJ} = 10\text{ }\mu\text{F}$	66	80	

1. C_{ADJ} is connected between adjust pin and ground.

$V_1 - V_O = 5 \text{ V}$, $I_O = 500 \text{ mA}$, $I_{MAX} = 1.5 \text{ A}$ and $P_{MAX} = 20 \text{ W}$, $T_J = -40$ to $125 \text{ }^\circ\text{C}$, unless otherwise specified.

Table 5. Electrical characteristics for LM317B

Symbol	Parameter	Test conditions	Min.	Typ.	Max.	Unit
ΔV_O	Line regulation	$V_1 - V_O = 3$ to 40 V	$T_J = 25^\circ\text{C}$	0.01	0.04	%V
				0.02	0.07	
ΔV_O	Load regulation	$V_O \leq 5 \text{ V}$ $I_O = 10 \text{ mA}$ to I_{MAX}	$T_J = 25^\circ\text{C}$	5	25	mV
				20	70	
		$V_O \geq 5 \text{ V}$, $I_O = 10 \text{ mA}$ to I_{MAX}	$T_J = 25^\circ\text{C}$	0.1	0.5	%
				0.3	1.5	
I_{ADJ}	Adjustment pin current		50	100	μA	
ΔI_{ADJ}	Adjustment pin current	$V_1 - V_O = 2.5$ to 40 V $I_O = 10 \text{ mA}$ to 500 mA		0.2	5	μA
V_{REF}	Reference voltage (between pin 3 and pin 1)	$V_1 - V_O = 2.5$ to 40 V $I_O = 10 \text{ mA}$ to 500 mA $P_D \leq P_{MAX}$	1.2	1.25	1.3	V
$\Delta V_O/V_O$	Output voltage temperature stability			1		%
$I_{O(min)}$	Minimum load current	$V_1 - V_O = 40 \text{ V}$		3.5	10	mA
$I_{O(max)}$	Maximum load current	$V_1 - V_O \leq 15 \text{ V}$, $P_D < P_{MAX}$	1.5	2.2		A
		$V_1 - V_O = 40 \text{ V}$, $P_D < P_{MAX}$, $T_J = 25^\circ\text{C}$	0.4			
eN	Output noise voltage (percentage of V_O)	$B = 10 \text{ Hz}$ to 100 kHz , $T_J = 25^\circ\text{C}$		0.003		%
SVR	Supply voltage rejection ⁽¹⁾	$T_J = 25^\circ\text{C}$, $f = 120 \text{ Hz}$	$C_{ADJ} = 0$	65		dB
			$C_{ADJ} = 10 \mu\text{F}$	66	80	

1. C_{ADJ} is connected between adjust pin and ground.

5 Typical characteristics

Figure 3. Output current vs. input-output differential voltage

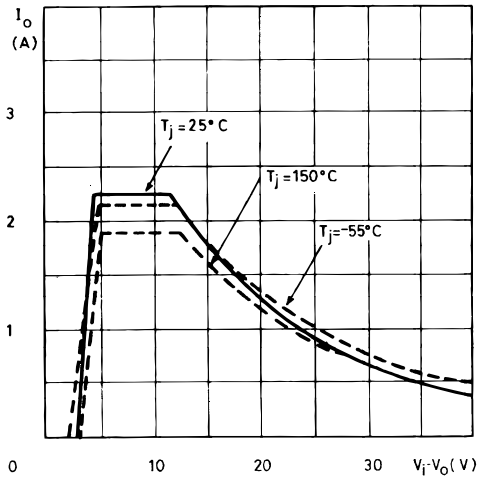

Figure 4. Dropout voltage vs. junction temperature

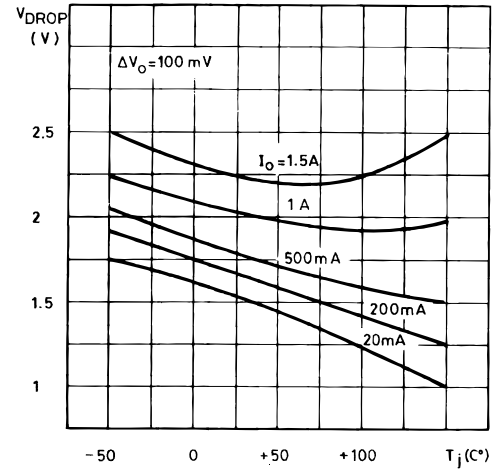

Figure 5. Reference voltage vs. junction

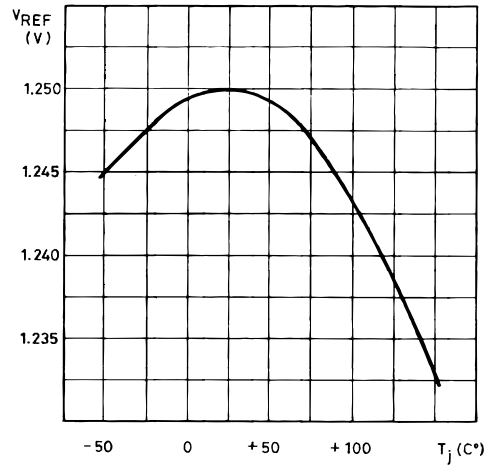
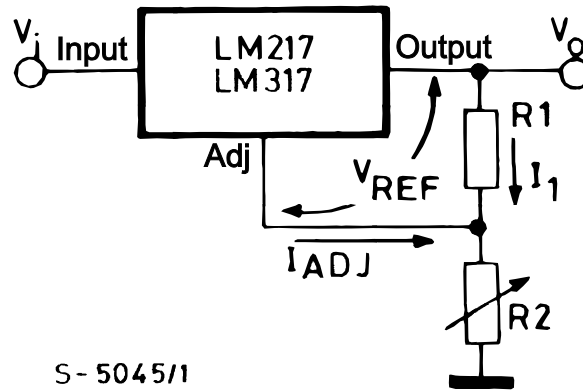

Figure 6. Basic adjustable regulator



S-5045/1

6 Application information

The LM217, LM317 provides an internal reference voltage of 1.25 V between the output and adjustments terminals. This is used to set a constant current flow across an external resistor divider (see Figure 6. Basic adjustable regulator), giving an output voltage V_O of:

$$V_O = V_{REF} (1 + R_2/R_1) + I_{ADJ} R_2$$

The device was designed to minimize the term I_{ADJ} (100 μ A max) and to maintain it very constant with line and load changes. Usually, the error term $I_{ADJ} \times R_2$ can be neglected. To obtain the previous requirement, all the regulator quiescent current is returned to the output terminal, imposing a minimum load current condition. If the load is insufficient, the output voltage will rise. Since the LM217, LM317 is a floating regulator and "sees" only the input-to-output differential voltage, supplies of very high voltage with respect to ground can be regulated as long as the maximum input-to-output differential is not exceeded. Furthermore, programmable regulators are easily obtainable and, by connecting a fixed resistor between the adjustment and output, the device can be used as a precision current regulator. In order to optimize the load regulation, the current set resistor R_1 (see Figure 6. Basic adjustable regulator) should be tied as close as possible to the regulator, while the ground terminal of R_2 should be near the ground of the load to provide remote ground sensing. Performance may be improved with added capacitance as follow:

- An input bypass capacitor of 0.1 μ F
- An adjustment terminal to ground 10 μ F capacitor to improve the ripple rejection of about 15 dB (C_{ADJ}).
- An 1 μ F tantalum (or 25 μ F Aluminium electrolytic) capacitor on the output to improve transient response. In addition to external capacitors, it is good practice to add protection diodes, as shown in figure below D1 protect the device against input short circuit, while D2 protect against output short circuit for capacitance discharging.

Figure 7. Voltage regulator with protection diodes

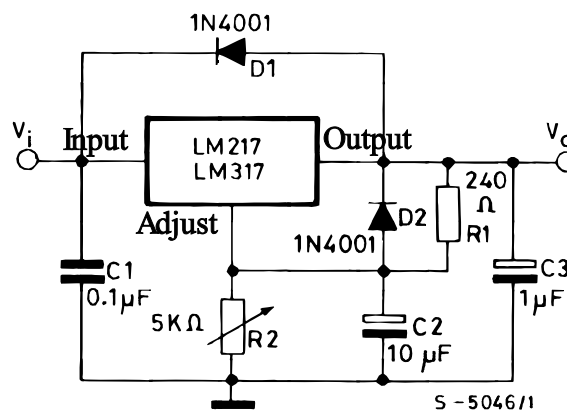

Note: D1 protect the device against input short circuit, while D2 protects against output short circuit for capacitors discharging.

Figure 8. Slow turn-on 15 V regulator

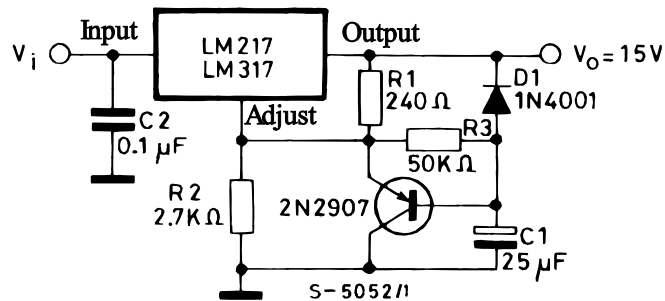
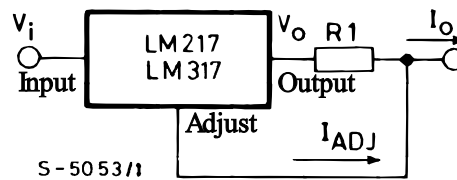

Figure 9. Current regulator



$$I_O = (V_{REF} / R_1) + I_{ADJ} = 1.25 \text{ V} / R_1$$

Figure 10. 5 V electronic shut-down regulator

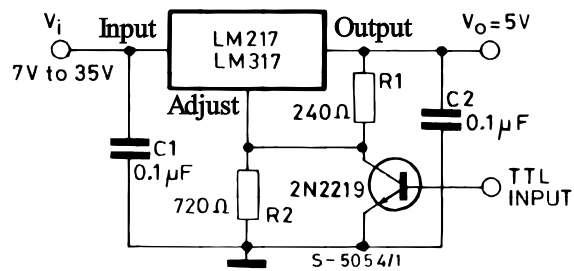
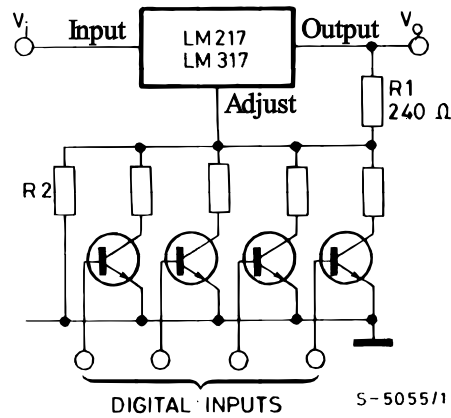
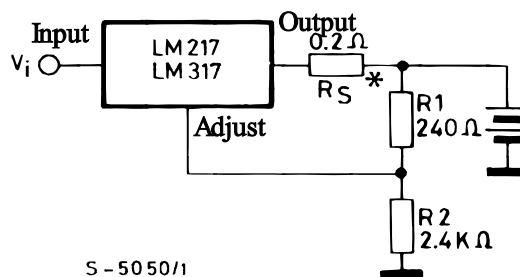

Figure 11. Digitally selected outputs



(R₂ sets maximum V_O)

Figure 12. Battery charger (12 V)



* R_S sets output impedance of charger $Z_O = R_S (1 + R_2 / R_1)$. Use of R_S allows low charging rates whit fully charged battery.

Figure 13. Current limited 6 V charger

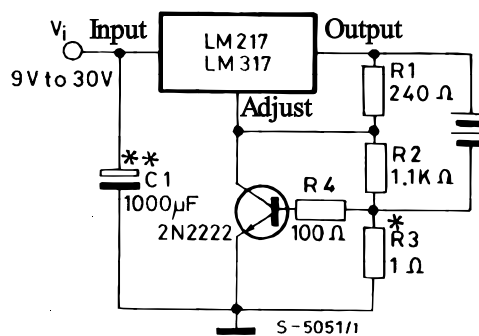

* R₃ sets peak current (0.6 A for 10).

** C₁ recommended to filter out input transients.

7 Device summary

Table 6. Device summary

Order codes			
TO-220 (single gauge)	TO-220 (double gauge)	D ² PAK (tape and reel)	TO-220FP
LM217T	LM217T-DG	LM217D2T-TR	
LM317T	LM317T-DG	LM317D2T-TR	LM317P
LM317BT			

8 Package information

In order to meet environmental requirements, ST offers these devices in different grades of ECOPACK packages, depending on their level of environmental compliance. ECOPACK specifications, grade definitions and product status are available at: www.st.com. ECOPACK is an ST trademark.

8.1 TO-220 (single gauge) package information

Figure 14. TO-220 (single gauge) package outline

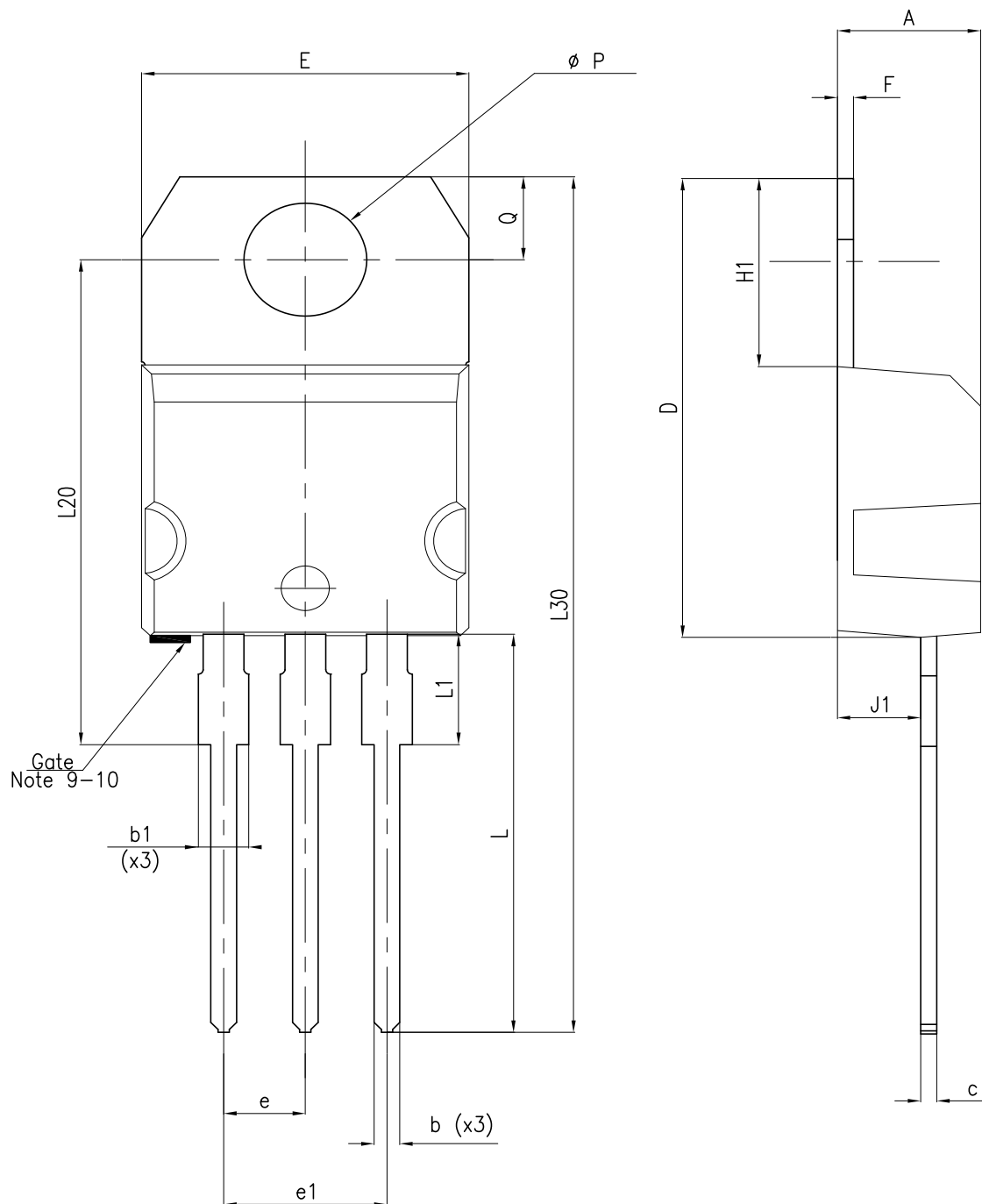

8174627_5

Table 7. TO-220 (single gauge) mechanical data

Dim.	mm		
	Min.	Typ.	Max.
A	4.40		4.60
b	0.61		0.88
b1	1.14		1.70
c	0.48		0.70
D	15.25		15.75
E	10.00		10.40
e	2.40		2.70
e1	4.95		5.15
F	0.51		0.60
H1	6.20		6.60
J1	2.40		2.72
L	13.00		14.00
L1	3.50		3.93
L20		16.40	
L30		28.90	
ØP	3.75		3.85
Q	2.65		2.95

8.2 TO-220 (dual gauge) package information

Figure 15. TO-220 (dual gauge) package outline

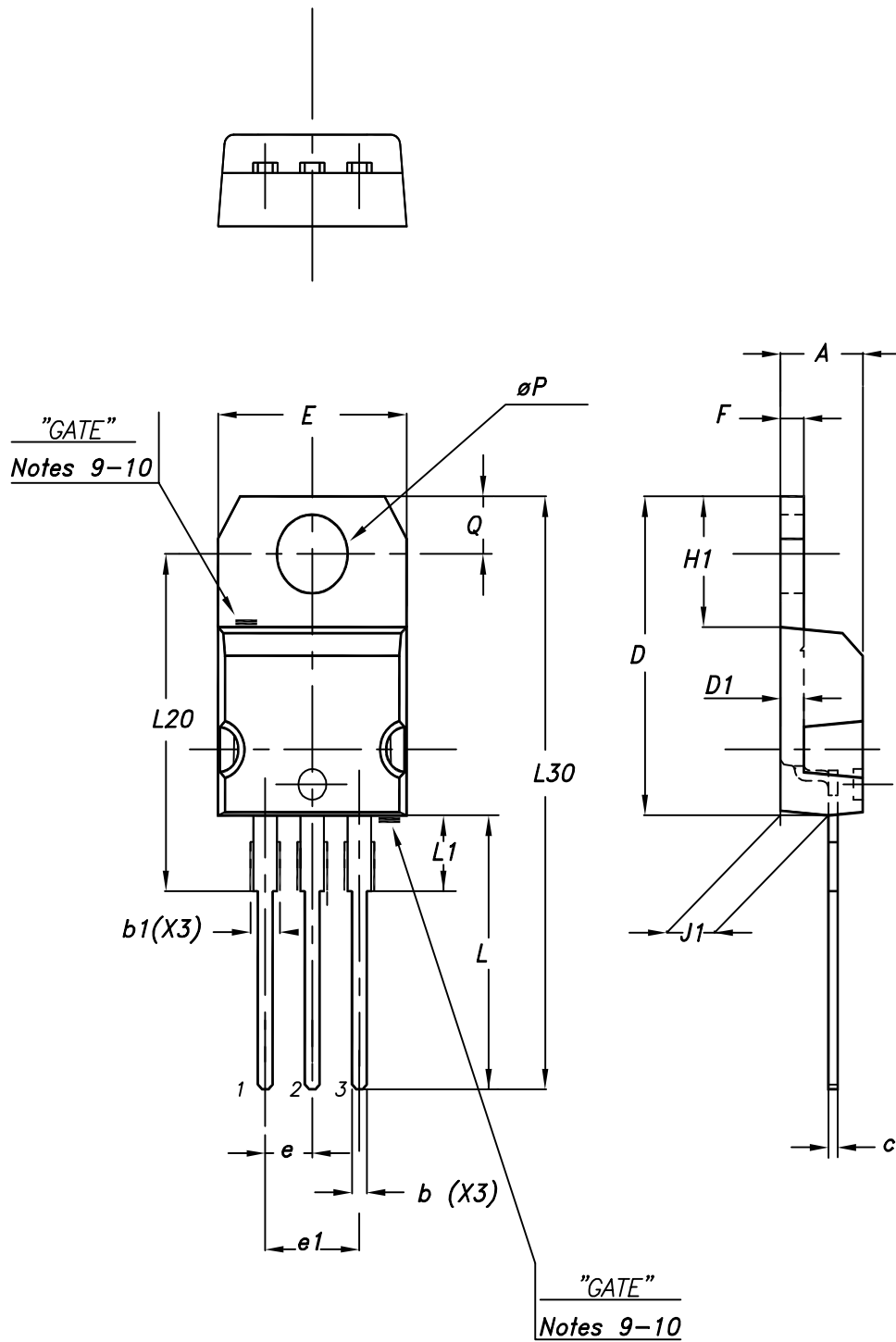

0015988_21_Type A

Table 8. TO-220 (dual gauge) mechanical data

Dim.	mm		
	Min.	Typ.	Max.
A	4.40		4.60
b	0.61		0.88
b1	1.14		1.70
c	0.48		0.70
D	15.25		15.75
D1		1.27	
E	10		10.40
e	2.40		2.70
e1	4.95		5.15
F	1.23		1.32
H1	6.20		6.60
J1	2.40		2.72
L	13		14
L1	3.50		3.93
L20		16.40	
L30		28.90	
∅P	3.75		3.85
Q	2.65		2.95

8.3 TO-220FP type A package information

Figure 16. TO-220FP package outline

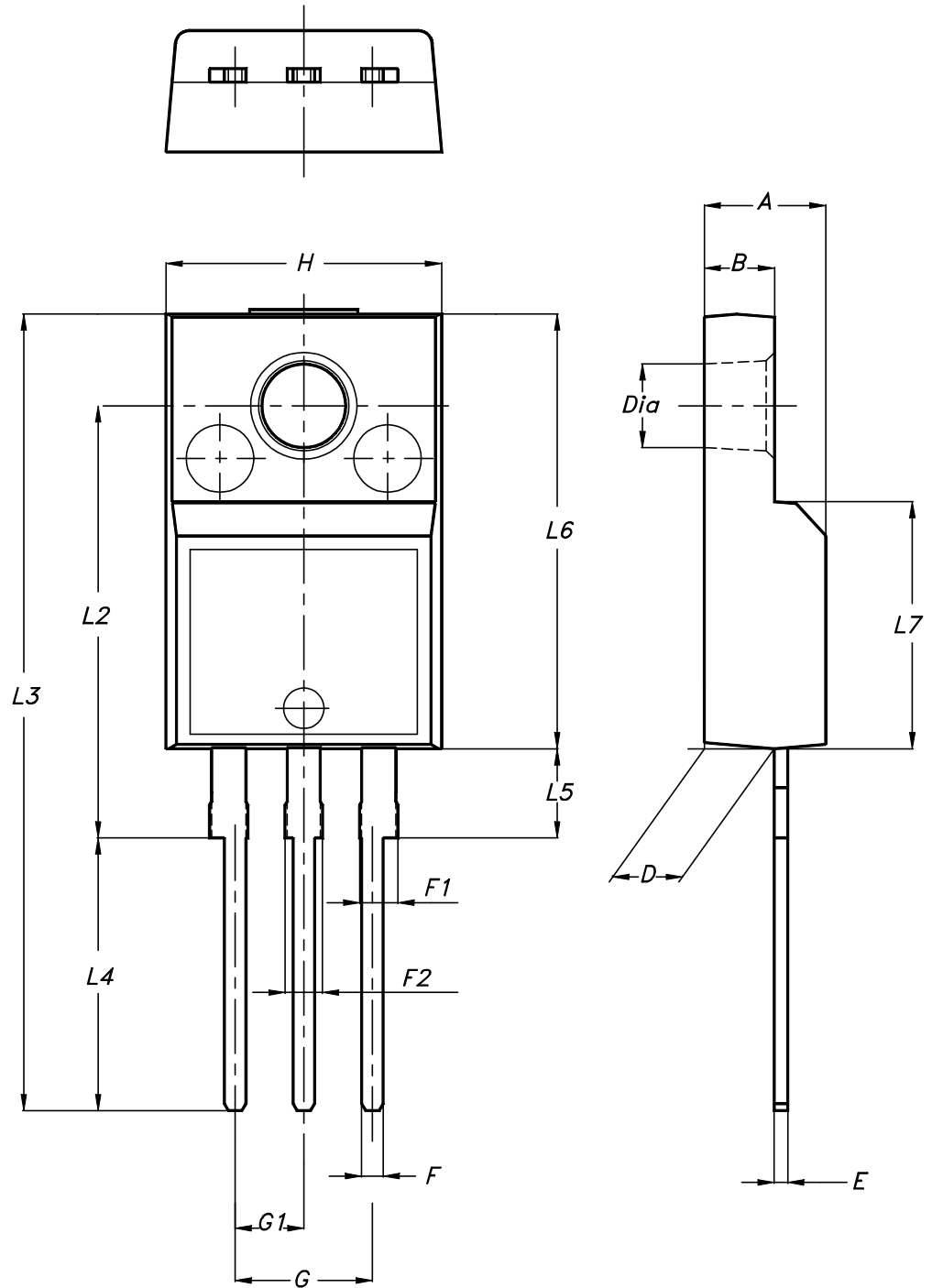

7012510_type_A

Table 9. TO-220FP package mechanical data

Dim.	mm		
	Min.	Typ.	Max.
A	4.4		4.6
B	2.5		2.7
D	2.5		2.75
E	0.45		0.7
F	0.75		1
F1	1.15		1.70
F2	1.15		1.70
G	4.95		5.2
G1	2.4		2.7
H	10		10.4
L2		16	
L3	28.6		30.6
L4	9.8		10.6
L5	2.9		3.6
L6	15.9		16.4
L7	9		9.3
Dia	3		3.2

8.4 D²PAK (SMD 2L STD-ST) type A package information

Figure 17. D²PAK (SMD 2L STD-ST) type A package outline

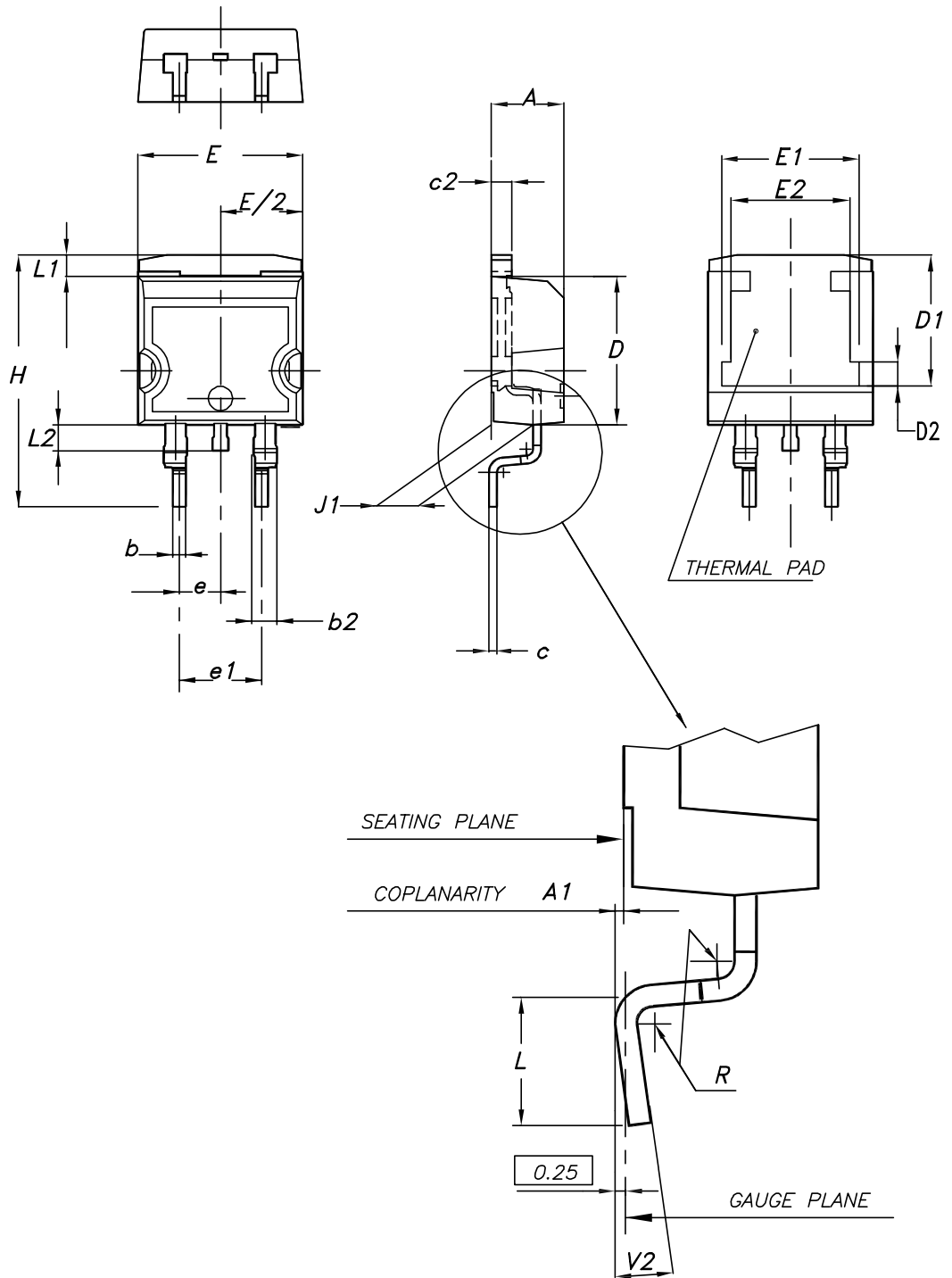

0079457_22_type A

Table 10. D²PAK (SMD 2L STD-ST) mechanical data

Dim.	mm		
	Min.	Typ.	Max.
A	4.40		4.60
A1	0.03		0.23
b	0.70		0.93
b2	1.14		1.70
c	0.45		0.60
c2	1.23		1.36
D	8.95		9.35
D1	7.50	7.75	8.00
D2	1.10	1.30	1.50
E	10		10.40
E1	8.50	8.70	8.90
E2	6.85	7.05	7.25
e		2.54	
e1	4.88		5.28
H	15		15.85
J1	2.49		2.69
L	2.29		2.79
L1	1.27		1.40
L2	1.30		1.75
R		0.4	
V2	0°		8°

8.5 D²PAK (ASE) type B package information

Figure 18. D²PAK (ASE subcon) type B package outline

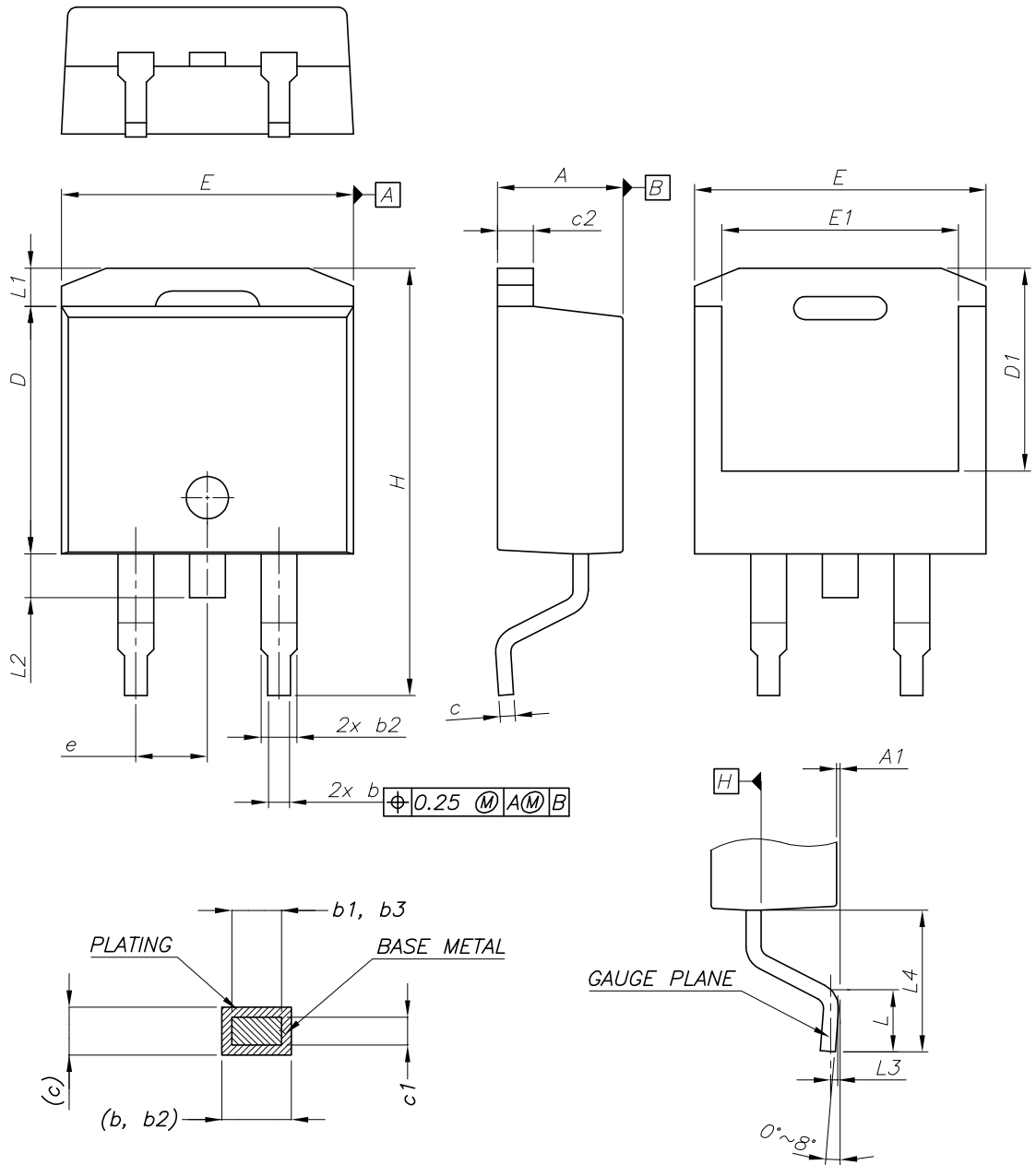

0079457_23_type B

Table 11. D²PAK (ASE) type B mechanical data

Dim.	mm		
	Min.	Typ.	Max.
A	4.36		4.56
A1	0		0.25
b	0.70		0.90
b1	0.51		0.89
b2	1.17		1.37
b3	1.36		1.46
c	0.38		0.694
c1	0.38		0.534
c2	1.19		1.34
D	8.60		9.00
D1	6.90		7.50
E	10.15		10.55
E1	8.10		8.70
e		2.54	
H	15.00		15.60
L	1.90		2.50
L1			1.65
L2			1.78
L3		0.25	
L4	4.78		5.28

Figure 19. D²PAK recommended footprint (dimensions are in mm)

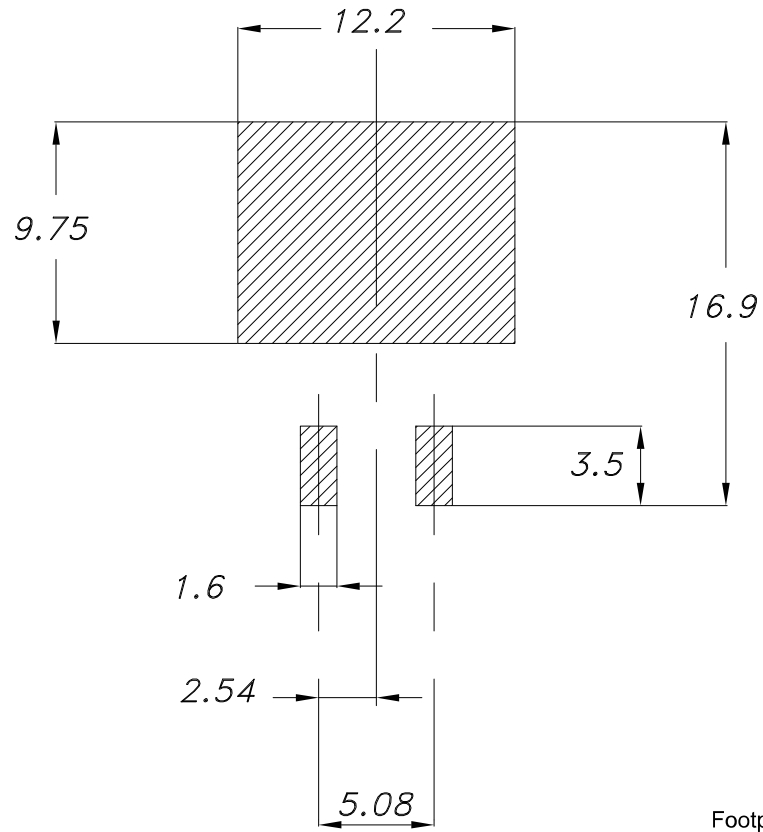

Footprint_0079457

8.6 D²PAK packaging information

Figure 20. D²PAK tape outline

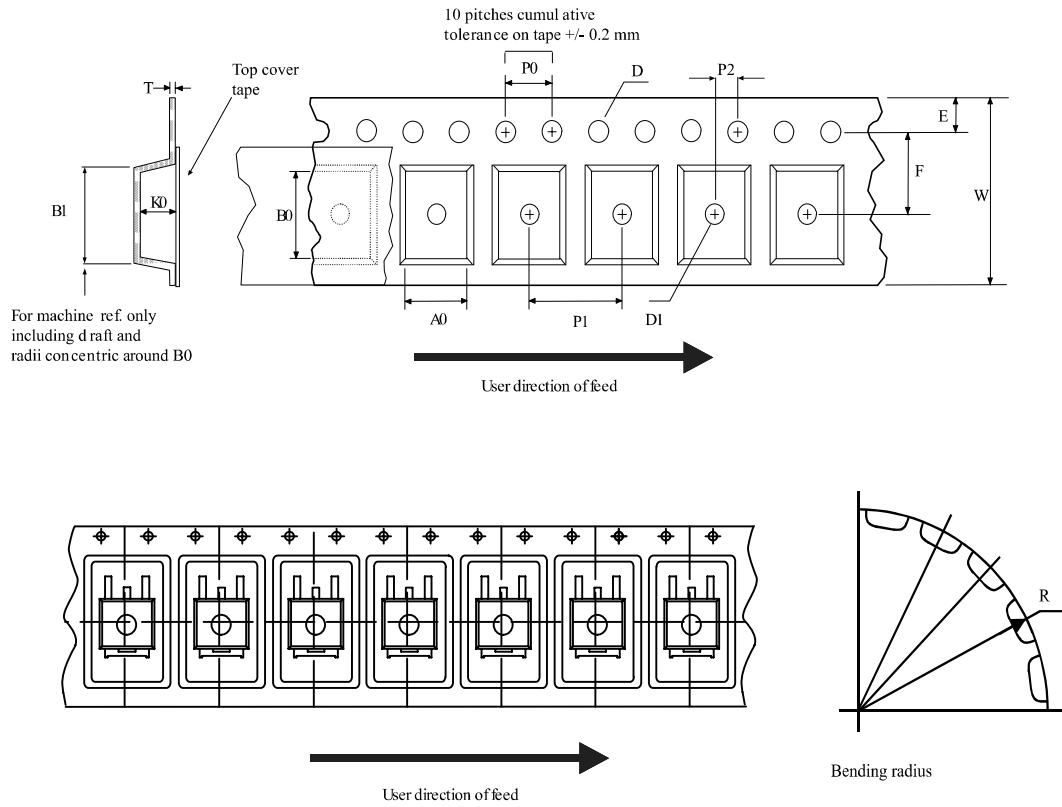

Figure 21. Reel for D²PAK

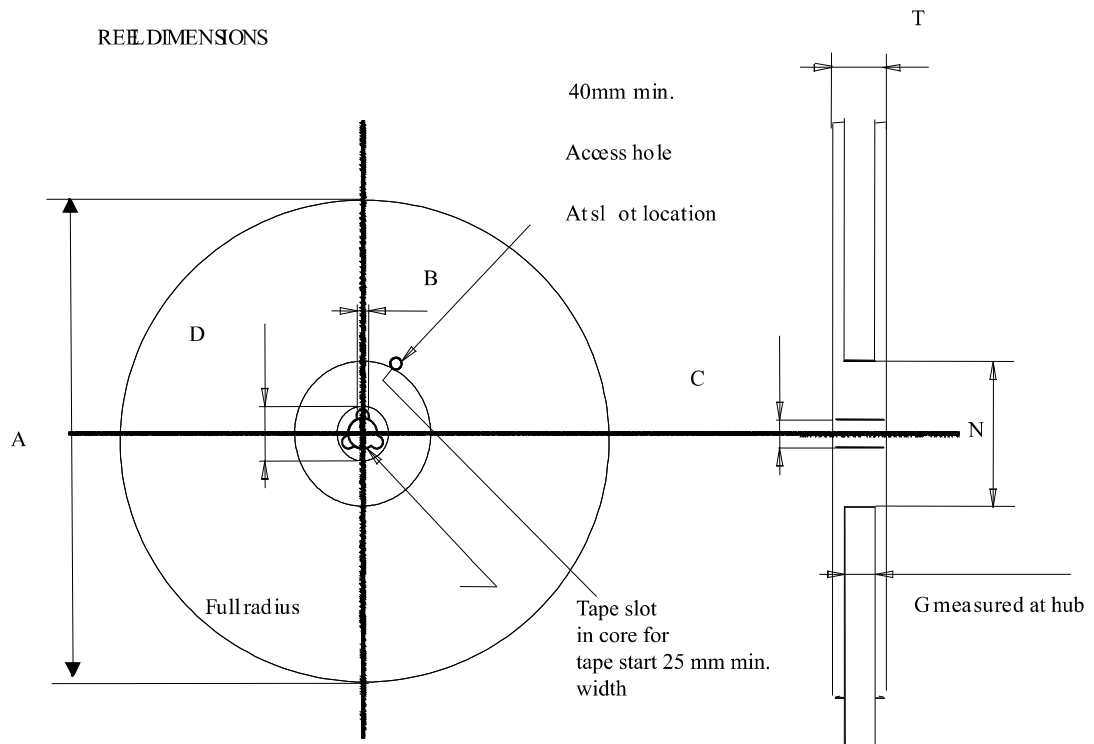

Table 12. D²PAK tape and reel mechanical data

Dim.	Tape		Dim.	Reel	
	mm			mm	
	Min.	Max.		Min.	Max.
A0	10.5	10.7	A		330
B0	15.7	15.9	B	1.5	
D	1.5	1.6	C	12.8	13.2
D1	1.59	1.61	D	20.2	
E	1.65	1.85	G	24.4	26.4
F	11.4	11.6	N	100	
K0	4.8	5.0	T		30.4
P0	3.9	4.1			
P1	11.9	12.1		Base qty	1000
P2	1.9	2.1		Bulk qty	1000
R	50				
T	0.25	0.35			
W	23.7	24.3			

Revision history

Table 13. Document revision history

Date	Revision	Changes
01-Sep-2004	10	Mistake VREF==> V _O , tables 1, 4 and 5.
19-Jan-2007	11	D ² PAK mechanical data has been updated, add footprint data and the document has been reformatted.
13-Jun-2007	12	Change values ΔI_{ADJ} and V _{REF} test condition of I _O = 10 mA to I _{MAX} ==> I _O = 10 mA to 500 mA on Table 5.
23-Nov-2007	13	Added Table 1.
06-Feb-2008	14	Added: TO-220 mechanical data Figure 14 on page 14 and Table 6 on page 13.
02-Mar-2010	15	Added: notes Figure 14 on page 14, Figure 15 on page 15, Figure 16 and Figure 17 on page 16.
17-Nov-2010	16	Modified: R _{thJC} value for TO-220 Table 3 on page 4.
18-Nov-2011	17	Added: order code LM317T-DG Table 1 on page 1.
13-Feb-2012	18	Added: order code LM217T-DG Table 1 on page 1.
12-Mar-2014	19	The part number LM117 has been moved to a separate datasheet. Removed TO-3 package. Updated the description in cover page Modified Table 1: Device summary, Table 3: Thermal data, Figure 1: Pin connections (top view), Section 4: Electrical characteristics, Section 5: Typical characteristics, Section 6: Application information, Section 7: Package mechanical data. Added Section 8: Packaging mechanical data. Minor text changes.
28-May-2018	20	Updated Section 8.5 D ² PAK (ASE) type B package information.
31-Jul-2019	21	Updated T _{OP} unit in Table 1. Absolute maximum ratings.

Contents

1	Pin configuration	2
2	Maximum ratings	3
3	Diagram	4
4	Electrical characteristics	5
5	Typical characteristics	8
6	Application information	10
7	Device summary	13
8	Package information	14
8.1	TO-220 (single gauge) package information	14
8.2	TO-220 (dual gauge) package information	15
8.3	TO-220FP type A package information	17
8.4	D ² PAK (SMD 2L STD-ST) type A package information	19
8.5	D ² PAK (ASE) type B package information	21
8.6	D ² PAK packing information	24
	Revision history	27

List of tables

Table 1.	Absolute maximum ratings	3
Table 2.	Thermal data	3
Table 3.	Electrical characteristics for LM217	5
Table 4.	Electrical characteristics for LM317	6
Table 5.	Electrical characteristics for LM317B	7
Table 6.	Device summary	13
Table 7.	TO-220 (single gauge) mechanical data	15
Table 8.	TO-220 (dual gauge) mechanical data	17
Table 9.	TO-220FP package mechanical data	19
Table 10.	D ² PAK (SMD 2L STD-ST) mechanical data	21
Table 11.	D ² PAK (ASE) type B mechanical data	23
Table 12.	D ² PAK tape and reel mechanical data	26
Table 13.	Document revision history	27

List of figures

Figure 1.	Pin connections (top view)	2
Figure 2.	Schematic diagram	4
Figure 3.	Output current vs. input-output differential voltage	8
Figure 4.	Dropout voltage vs. junction temperature	8
Figure 5.	Reference voltage vs. junction	8
Figure 6.	Basic adjustable regulator	9
Figure 7.	Voltage regulator with protection diodes	10
Figure 8.	Slow turn-on 15 V regulator	11
Figure 9.	Current regulator	11
Figure 10.	5 V electronic shut-down regulator	11
Figure 11.	Digitally selected outputs	12
Figure 12.	Battery charger (12 V)	12
Figure 13.	Current limited 6 V charger.	12
Figure 14.	TO-220 (single gauge) package outline	14
Figure 15.	TO-220 (dual gauge) package outline	16
Figure 16.	TO-220FP package outline.	18
Figure 17.	D ² PAK (SMD 2L STD-ST) type A package outline	20
Figure 18.	D ² PAK (ASE subcon) type B package outline	22
Figure 19.	D ² PAK recommended footprint (dimensions are in mm)	24
Figure 20.	D ² PAK tape outline	25
Figure 21.	Reel for D ² PAK	26

IMPORTANT NOTICE – PLEASE READ CAREFULLY

STMicroelectronics NV and its subsidiaries (“ST”) reserve the right to make changes, corrections, enhancements, modifications, and improvements to ST products and/or to this document at any time without notice. Purchasers should obtain the latest relevant information on ST products before placing orders. ST products are sold pursuant to ST’s terms and conditions of sale in place at the time of order acknowledgement.

Purchasers are solely responsible for the choice, selection, and use of ST products and ST assumes no liability for application assistance or the design of Purchasers’ products.

No license, express or implied, to any intellectual property right is granted by ST herein.

Resale of ST products with provisions different from the information set forth herein shall void any warranty granted by ST for such product.

ST and the ST logo are trademarks of ST. For additional information about ST trademarks, please refer to www.st.com/trademarks. All other product or service names are the property of their respective owners.

Information in this document supersedes and replaces information previously supplied in any prior versions of this document.

© 2019 STMicroelectronics – All rights reserved